



Generation of test aerosols from powders, pollen, and spores with integrated pump independent from pressurized air supply, mass flow approx. 0.04 – 800 g/h

## Description

Low-concentration solid particle aerosols produced from powders are required for many applications in research, development and quality assurance and for the calibration of particle measurement devices.

For more than 25 years, the RBG system has been used worldwide with great success for the reliable dispersion of non-cohesive powders such as mineral dusts, active pharmaceutical ingredients, pollen, etc. in the size range of  $< 100 \mu\text{m}$  and with a fine fraction of  $< 100 \text{ nm}$ . Monolithic solid materials such as blackboard chalk are finely dispersed with highest dosing constancy.

The special advantage of this dosing and dispersion system is that in the case of the RBG system, mass flows ranging from approx. 40 mg/h up to approx. 800 g/h are dispersed with the highest level of dosing constancy thanks to quick, easy exchange of the solid material reservoir.

RBG solo has an integrated pump and can be operated independently from compressed air supply.

### Start-up

The powder to be dispersed is filled little by little into the cylindrical solid material reservoir and compressed with a tamper. The Lucerne University determined an excellent reproducibility of the tamping density in the solid material reservoir with a deviation of 3.4 %. The filled solid material reservoir is inserted into the dispersing head of the RBG. The powder, which has thus been uniformly compressed across the filling level, is then conveyed onto a rotating brush at a precisely controlled feed rate. An adjustable volume flow streams over the tightly woven precision brush at a very high speed and tears the particles out of the brush. The dispersing head assembly consists of a dispersing holder, dispersing cover, precision brush, and solid material reservoir.

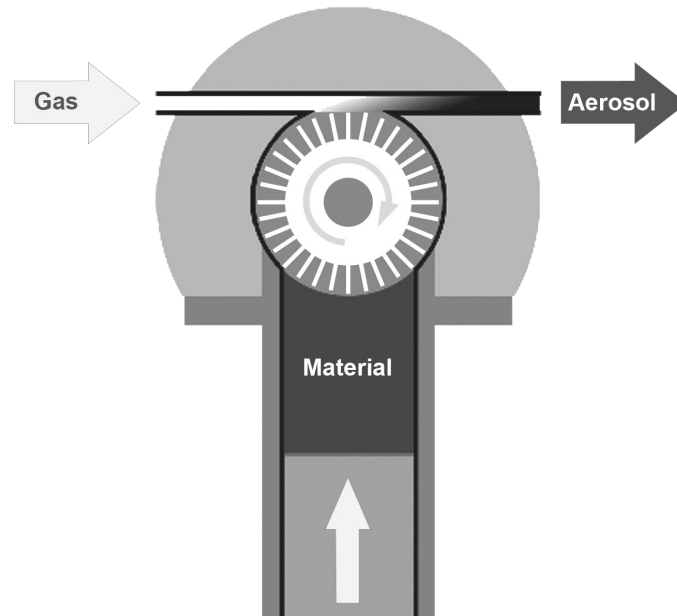

Fig. 1: Schematic diagram of RBG system

### Dosing

Dosing is performed via the precisely controlled feed rate of the feed piston. The desired mass flows can be easily and reproducibly specified based on the cross section of the solid material reservoir, the precisely adjustable feed rate of the feed piston and the easy-to-determine tamping density of the powder in the reservoir.

Reservoir diameter	Fill quantity	Feed rate 1 mm/h	Feed rate 10 mm/h	Feed rate 100 mm/h	Feed rate 1,000 mm/h
7 mm	2.7 g	38 mg/h	380 mg/h	3.8 g/h	38 g/h
10 mm	5.5 g	78 mg/h	780 mg/h	7.8 g/h	78 g/h
14 mm	17 g	150 mg/h	1.5 g/h	15 g/h	150 g/h
20 mm	35 g	310 mg/h	3.1 g/h	31 g/h	310 g/h
32 mm	88 g	800 mg/h	8 g/h	80 g/h	800 g/h

Table 2: Mass flows of RBG system (compacted density 1 g/cm<sup>3</sup>)

### Dispersing

The powder separated from the reservoir by the precision brush is almost completely dispersed into the constituent particles (see Fig. 2), in the dispersing head by the dispersing air flowing at high speed. The dispersing air flow is regulated automatically by an integrated mass-flow-control.

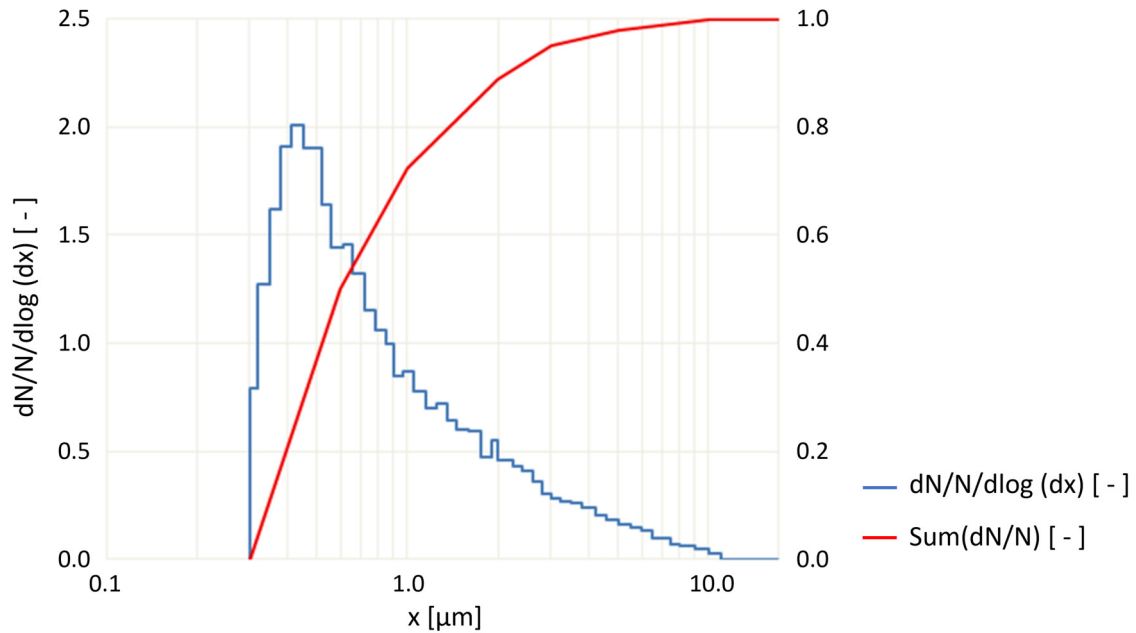

Fig. 2: Particle size distribution with the welas® digital 2000

Four different dispersing covers can be used for optimal dispersion.

Cover	Particle size	Reservoir diameter	Volume flow	Feed rate 100 mm/h	Feed rate 1,000 mm/h
A	< 0.1 - 100 μm	7 - 32 mm	33 - 80 l/min	3,8 g/h	38 g/h
B	< 0.1 - 100 μm	7, 10 and 14 mm	17 - 40 l/min	7.8 g/h	78 g/h
C	< 0.1 - 100 μm	7 mm	8 - 20 l/min	15 g/h	150 g/h
D	200 - 1,000 μm	7 - 32 mm	33 - 80 l/min	31 g/h	310 g/h
32 mm	88 g	800 mg/h	8 g/h	80 g/h	800 g/h

Table 4: Dispersion covers RBG system

### Pulse mode

The construction design of the RBG system allows for operation in "powder"/"no powder" pulse mode with cycle lengths ranging down to a second. The function can be used manually on the unit or via a connected computer.

### Remote control

RBG solo can be optionally controlled via the delivered software from a Windows computer or tablet.

## Benefits

- Very high short-term and long-term dosing constancy
- Dispersion of virtually all non-cohesive dusts
- Easy and fast exchange of different solid material reservoirs and dispersing covers
- Integrated pump replaces compressed air supply
- Automatic determination and adjustment of the mass flow
- Pulse mode
- All unit parameters on LCD-display at a glance
- Remote operation with included software
- Device easy to clean
- Little maintenance required
- Low operating expenses

## Datasheet

<i>Parameter</i>	<i>Description</i>
<b>Volume flow</b>	8 – 40 NI/min
<b>Interfaces</b>	USB type B
<b>Weight</b>	Approx. 19 kg
<b>Particle material</b>	Non-cohesive powders and bulks
<b>Dosing time</b>	Several hours nonstop
<b>Maximum particle number concentration</b>	Approx. $10^7$ particles/cm <sup>3</sup>
<b>Mass flow (particles)</b>	0.04 – 800 g/h (with an assumed compacted density of 1 g/cm <sup>3</sup> )
<b>Particle size range</b>	0.1 – 100 μm
<b>Carrier/dispersion gas</b>	Air, nitrogen
<b>Feed rate</b>	1 – 1,000 mm/h
<b>Reservoir inner diameter</b>	7, 10, 14, 20, 32 mm
<b>Maximum counter pressure</b>	0.1 barg
<b>Filling height</b>	110 mm
<b>Dispersion cover</b>	Type A, type B, type C, type D
<b>Compressed air connection</b>	Quick coupling
<b>Aerosol outlet connection</b>	Øinside= 5 mm, Øoutside = 8 mm
<b>Power supply</b>	115 – 230 V, 50/60 Hz
<b>Dimensions</b>	515 • 330 • 240 mm (H • W • D)
<b>Filling quantity</b>	2.7 g (reservoir Ø = 7 mm), 5.5 g (reservoir Ø = 10 mm), 17 g (reservoir Ø = 14 mm), 35 g (reservoir Ø = 20 mm), 88 g (reservoir Ø = 32 mm) (with an assumed compacted density of 1 g/cm <sup>3</sup> )

## Applications

- Filter industry:
  - Determination of fractional separation efficiency
  - Determination of total separation efficiency
  - Long-term dusting
  - Filter media and ready-made filters
  - Dust removal filters
  - Vacuum cleaners and vacuum cleaner filters
  - Car interior filters
  - Engine air filters
- Calibration of particle measurement devices
- Flow visualization
- Inhalation tests
- Tracer particles for LDA, PIV, etc.
- Coating of surfaces

**Palas GmbH**  
Partikel- und Lasermesstechnik  
Greschbachstrasse 3 b  
**76229 Karlsruhe**  
Germany

**Managing Partner:**  
Dr.-Ing. Maximilian Weiß, Udo Fuchslocher  
**Commercial Register:**  
register court: Mannheim  
company registration number: HRB 103813  
USt-Id: DE143585902



**Contact:** E-Mail: [mail@palas.de](mailto:mail@palas.de) Internet: [www.palas.de](http://www.palas.de) Tel: +49 (0)721 96213-0 Fax: +49 (0)721 96213-33